

## DESCRIPTION

The GS-302 is a compact Garden Speaker ideal for paging and background music broadcast in such places as gardens, theme parks and resort facilities. Corrosion resistant material is adopted to the speaker exterior, ensuring prolonged use of the speaker in a water-splashed environment.

The appearance of Garden Speaker is designed so inconspicuous that the speaker can be installed in shrubberies of garden blending with the surroundings.

## SPECIFICATIONS

Enclosure	Sealed type
Rated Input	30 W (100 V line), 15 W (70 V line)
Rated Impedance	100 V line: 330 Ω (30 W), 670 Ω (15 W), 1 kΩ (10 W), 2 kΩ (5 W), 3.3 kΩ (3 W) 70 V line: 330 Ω (15 W), 670 Ω (7.5 W), 1 kΩ (5 W), 2 kΩ (2.5 W), 3.3 kΩ (1.5 W)
Sensitivity	87 dB (1 W, 1 m)
Frequency Response	100 - 8,000 Hz
Speaker Component	12 cm splash-proof cone-type
Input Terminal	Push-in terminal
Applicable Cable	Solid copper wire: $\phi 0.8 - \phi 1.6$ mm, Stranded cooper wire: 0.75 - 1.25 mm <sup>2</sup>
Water Capability	Equivalent to IPX4
Finish	Top cover and base: FRP resin, dark gray, semi-gloss, paint Speaker panel: ABS resin, dark gray, semi-gloss, paint Legs: Aluminum, dark gray, semi-gloss, paint
Dimensions	$\phi 270 \times 335$ (H) mm
Weight	2.4 kg
Accessory	TOA label --2

## APPEARANCE

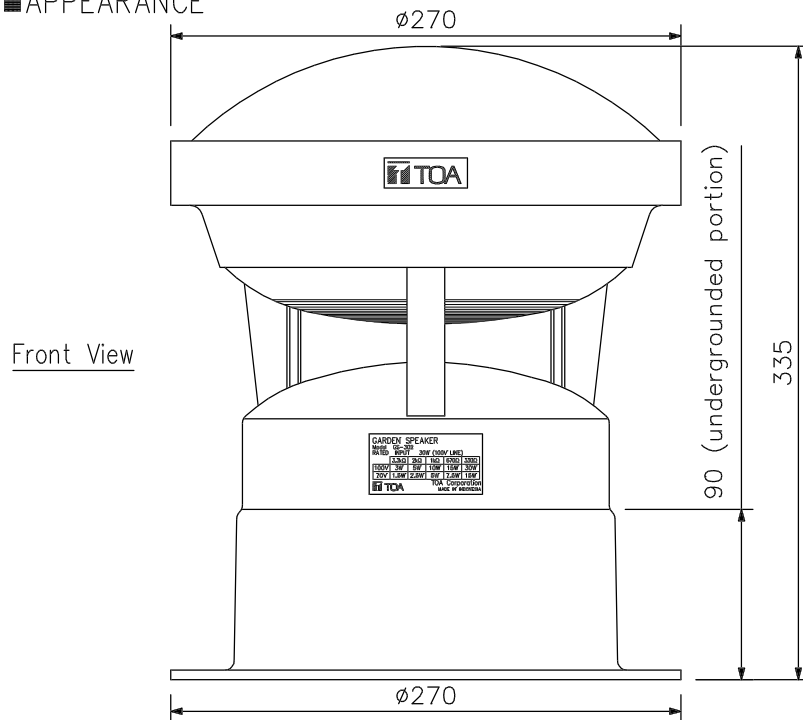

Front View

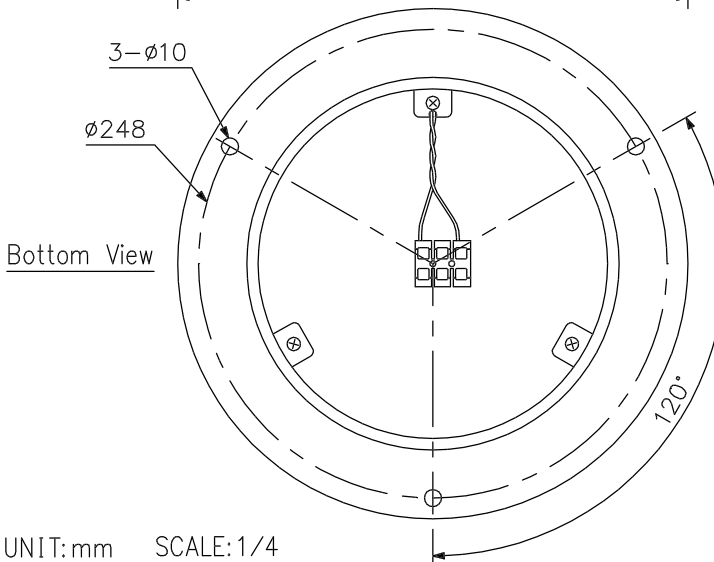

Bottom View

UNIT:mm SCALE:1/4

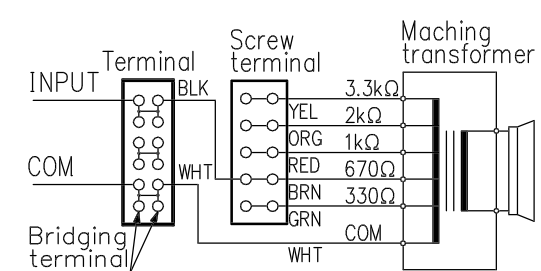

(Transformer connection when the speaker is supplied from the factory)

Wiring Diagram